

# DIESEL PARTICULATE FILTERS

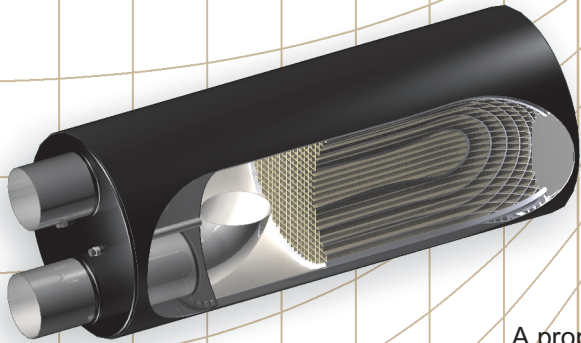

## CATALYZED FILTER TECHNOLOGY

Diesel filters utilize cordierite and silicon carbide wall-flow monoliths to trap the soot produced by diesel engines. The cylindrical filter element consists of many parallel channels running in the axial direction, separated by thin porous walls. The channels are open at one end and plugged at the other, forcing the particle laden exhaust gases to flow through the walls. Gases are able to escape through the pores in the wall material, but particulates are too large to escape and are trapped in the filter walls.

A proprietary catalyst is coated onto the inside surface of the filter monolith. The catalyst lowers the soot combustion temperature allowing the filter to regenerate. The accumulated soot is oxidized in the filter during regular operation of the engine. Exhaust temperatures of 275-300°C (530-575°F) for 25-30% of the operation time are necessary for proper filter regeneration, if ULSD (ultra-low sulfur diesel) fuel is used. This can be met on most heavy-duty diesel engine applications, as well as on some medium and light duty engines. Nett filters can be used with all fuels, regardless of sulfur content, however, higher exhaust temperatures will be required for regeneration.

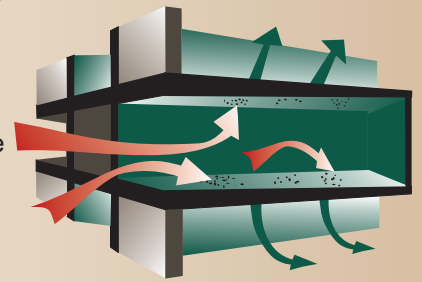

## FILTER EFFICIENCY

The particulate matter filtration efficiency of the catalyzed diesel filter typically exceeds 90%. The filtration efficiency of the elemental carbon fraction of diesel particulates (soot) is 95-99%.

Due to the presence of the catalyst, the filter typically reduces 70-90% (depending on exhaust temperature) of hydrocarbon and carbon monoxide emissions, respectively.

Typical exhaust gas pressure drop on a properly regenerating filter is between 5 and 10 kPa (20-40 in H<sub>2</sub>O).

Applications on new diesel engines with low engine-out particulate emissions or with higher exhaust temperatures regenerate better, accumulate less soot in the filter, and experience lower pressure drop.

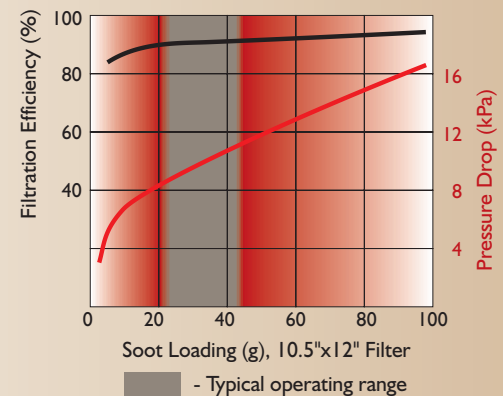

**NETT**  
NETT TECHNOLOGIES INC.  
2-6707 Goreway Drive  
Mississauga, ON L4V 1P7 Canada  
[www.nett.ca](http://www.nett.ca)  
e-mail: [sales@nett.ca](mailto:sales@nett.ca)  
tel: 905.672.5453 fax: 905.672.5949  
toll-free (North America): 800.361.6388

Technical data and information regarding the products described in this brochure is believed to be reliable. However, no representation or warranty is made with respect thereto except as made by Nett® Technologies Inc. in writing at the time of sale. © 2008 Nett® Technologies Inc.

**...the emission control authority.**